

Closed Circuit Visual Check Fuel Sampler

Applications

- Provides a 'Clear & Bright' visual examination of fuel.
- Enables the temperature and density of a sample to be measured (with optional thermometer, hydrometer and housing).
- Enables the dryness of the sample to be checked using the Shell Water Detector or the Exxon Hydrokit (with optional self sealing valve).

Capacities Available

Standard units are 2, 3.3, 4, 6 and 8 litres.

Features

- Aluminium body, Boron silicate glass.
- High Nitrile Seals.

Options

- Thermometer and hydrometer housing.
- Self-sealing valve for Shell Water (Detector or Exxon Hydrokit).
- Flameproof backlamp and shroud.
- Spring-close (deadman type) VCFS fill valve.



Specification

The Visual Check Fuel Sampler (VCFS) is a closed circuit fuel sampling system designed to provide a safe, easy and convenient method of carrying out the industry standard 'Clear & Bright' visual examination of aviation fuel.

The vessel consists of a strong, clear glass tube sandwiched between a base and a hinged lid assembly. The base incorporates a drain valve, a fill port, a hydrokit sampler draw off connection and a mounting flange. The internal surface of the base is conical in profile and finished in a white epoxy coating to assist visual detection of free water and/or dirt particles. The fill port is designed to cause the fuel sample to swirl around the sides of the glass tube; the resultant vortexing effect causes any solid contaminants to concentrate towards the centre of the glass to assist visual detection.

The mechanical design of the VCFS prevents vibration and thermal expansion from overstressing the glass tube. The hinged lid is large enough to allow a hand to reach inside the VCFS to enable the glass tube and base to be wiped clean for ease of maintenance and assured performance.

All vessels are offered with a range of options allowing bespoke functionality for the end user, at affordable prices, using proven standard designs.



Closed Circuit Visual Check Fuel Sampler

Technical Data

The Visual Check Fuel Sampler (VCFS) is a closed circuit fuel sampling system and is designed to provide a safe, easy and convenient method of carrying out the classic and widely used 'Clear & Bright' visual examination of aircraft fuel. The 3.3 litre unit is termed a 'Standard' VCFS being the optimum size for vehicle applications, large enough to obtain a complete sample yet sufficiently compact to fit unobtrusively on a small hydrant dispenser. The mechanical design of the VCFS prevents vibration and thermal expansion from over stressing the glass tube. The hinged lid is large enough to allow a hand to reach inside the VCFS to enable the glass and base to be wiped clean.

Options

- Housings are available to suspend within the VCFS enclosure to accept a thermometer and hydrometer.
- A self sealing valve assembly is available which allows the Shell Water Detector (syringe and capsule) or Exxon Hydrokit (evacuated glass tube) to draw a fuel sample from the base of the VCFS.
- A small handpump and non return valve are available if the VCFS cannot be gravity drained.
- A flame proof lamp is available complete with mounting bracket (to be positioned behind the VCFS glass tube for night operation).

	2 Litre	Standard 3.3 Litre	4 Litre	6 Litre	8 Litre
Thermometer and Hydrometer housing					
Exxon Hydro Kit					
Shell Water detector					
Handpump and non return valves					
Flameproof Lamp					
Replacement Glass					

Hydrometer and Thermometer (to suit housing) are available as optional items on request.

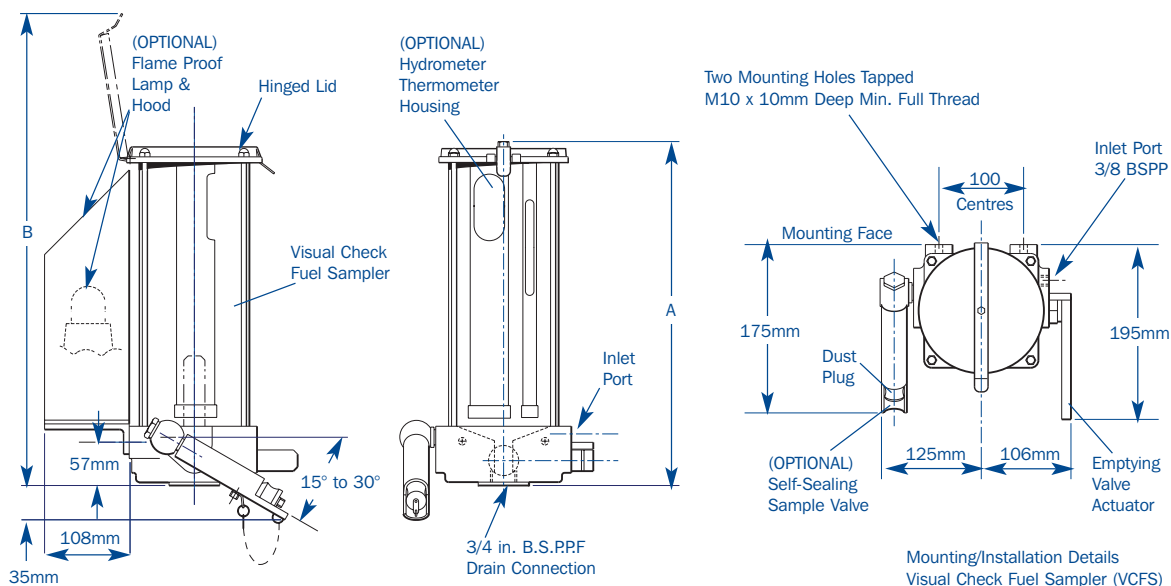

Dimensions

	2 Litre	Standard	4 Litre	6 Litre	8 Litre
Unit height (lid closed) (A)	280mm	400mm	465mm	555mm	825mm
Unit height (lid open) (B)	440mm	560mm	625mm	715mm	985mm
Weight(dry)	3.3 Kg	4.0 Kg	4.2 Kg	6.3 Kg	8.4 Kg